

Parkland™ Plastics

INSTALLATION GUIDE

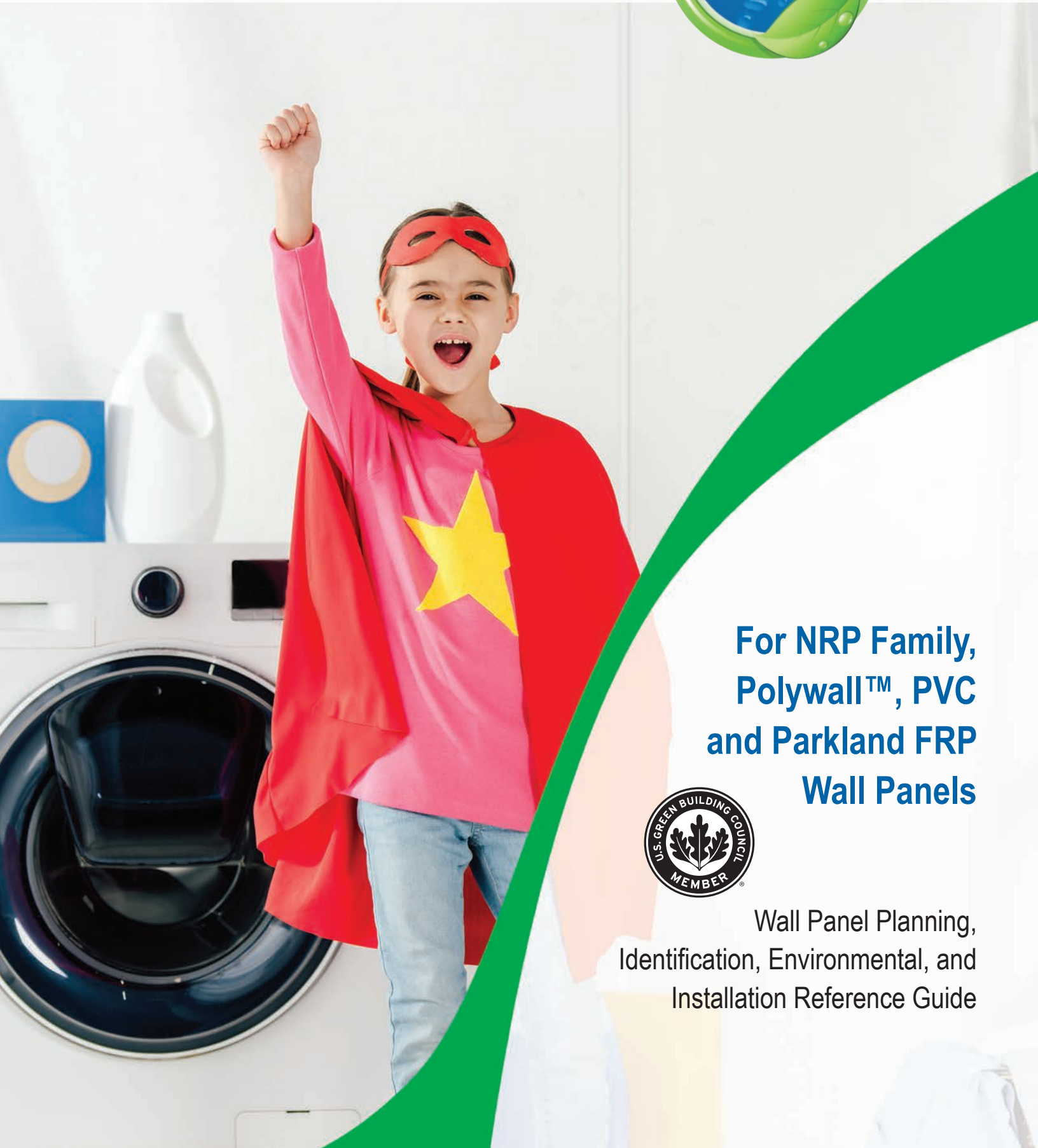

For NRP Family,
Polywall™, PVC
and Parkland FRP
Wall Panels



Wall Panel Planning,
Identification, Environmental, and
Installation Reference Guide

Sections

General Information	3
Safety Precautions, Supplies, Equipment and Storage Information	
Installation Preparation	4-7
Wall Preparation, Panel Layout, Choose an Adhesive, Environmental Considerations	
Subwall Identification and Planning	7
Identifying, and preparing for different subwall surfaces and how this affects adhesives	
Pre-Installation Planning	7
Panel selection, Performance Panel systems and Walls	
Basic NRP Panel Installation Steps	7-8
Step-by-step guide for normal installations	
Cutting Instructions	8
Panel trimming by panel type, hole and penetration guidelines	
Attaching to Wall	8-9
Adhesive, Fasteners, Spacing, Panel Sequence, Panel Finishing	
Seam Treatment Options	9-13
1-piece and 2-piece Moldings, Sealant Guide, Fasteners	
Specialty Installations	13-14
Waterproof Panels and Wet Areas, Decorative Installations, Laminated Panels, Masonry Substrates	
Product Identifier	14
Identify, differentiate, and understand all Parkland Wall Panel Products	
Use and Care Guide	15-16
Use, Application, care and cleaning Parkland Panel Products	

Disclaimer

PLEASE READ ALL INSTRUCTIONS BEFORE BEGINNING INSTALLATION

The recommendations provided in this bulletin represent our best judgment based on our experience with normal applications. The manufacturer and distributor of these products bear no responsibility for installer's actions taken or not taken. There are many subtleties to installation that are assumed and required for a professional installation, and such subtleties are not included in these instructions. This installation guide requires use by an experienced commercial installer with proper qualifications, and assumes adherence to all applicable codes. As such, these guidelines are strictly recommendations and are not intended to serve as a step-by-step, fool-proof installation checklist. Selection of an experienced FRP installer is the sole responsibility of the project owner. Parkland Plastics does not accept any responsibility for job failure resulting from any labor, installer or other field-related factor or error. Performance of the installation to be per the experience and judgment of the installation professional per actual field conditions and the desires of the end user.

PROFESSIONAL USE ONLY

PROFESSIONAL USE ONLY

PROFESSIONAL USE ONLY

Parkland- The Natural Choice

NRP, NRP-FR, Polywall, PVC, and PLAS-TEX®, and FRP Wall Panels comprise the most selections, choices, available at the most competitive prices, are natural-material reinforced interior wall panels and are 100% fiberglass-free. Parkland invented the reclaimed polymer wall panel and this proud tradition continues today with VOC-free materials and adhesives, all of which are available at modest cost. See www.parklandplastics.com for more information.

NOTE: Please contact your local Parkland Representative for a field exemption of alternative methods of installation.

General Information

Safety Information

WHEN CUTTING OR DRILLING, ALWAYS WEAR PROTECTIVE GLASSES OR GOGGLES AND A FACE MASK WHICH COVERS THE FACE AND MOUTH. Nearly all our panels are fiberglass-free, but when working with Parkland FRP, you can avoid itching due to glass fibers may be the use of barrier creams on exposed skin areas. Hearing protection is recommended for all wall panel work.

Supplies and Equipment

Supplies will vary depending on wall substrate, adhesive choice and seam treatment selection.

STANDARD NRP TOOLS NEEDED

- Standard 1/16" V-notched trowel for smooth primed drywall wall
- 1/8" V-notched trowel for unfinished, unprimed drywall, wood, and similar substrates
- 3/16" square-notched trowel for masonry subwalls- see masonry wall installation section.
- Circular saw with fine tooth carbide-tipped saw blade
- Swivel-head 18 gauge shears
- Drywall Roto-Zip® or similar rotary cutting tool
- Jig-Saw with metal-cutting fine blade
- Flat edge finishing tool (putty knife, 5-way painter's tool, or equivalent)
- Utility knife
- Level and straight edge
- PPE (personal protective equipment), including dust mask, gloves, shatterproof goggles

MATERIALS NEEDED

- **Parkland Plastics NRP®, NRP-FR, Polywall, PVC, or Parkland FRP Panels**
- **Use Parkland Panel Adhesive**, or you may use an approved adhesive from the chart on page 5.
- Soap and water for clean-up (Latex or Polymer adhesives)
- Saw horses
- Plywood larger than panels
- Dry, lint-free rags
- Sandpaper or Paper Tiger® Wallpaper Removal Tool for roughing up wall
- Tape measure
- Six-penny finishing nails
- Carbide tipped laminate cutter
- Grease Pencil to mark panels. **DO NOT MARK ON FACES OF PANELS WITH PENCIL.**
- **IMPORTANT NOTE:** If installation room has high humidity (65% or higher) then a portable low-cost dehumidifier unit is suggested.

SEAM TREATMENT OPTIONS

- Panel and Molding method (1-piece and 2-piece) See panel and molding chart on Page 6
- Panel and Sealant method (Parkland FPR only) - see recommended sealant chart on page 16.

Storage and handling

Panels should be stored indoors on a solid, flat, dry surface other than the floor. Do not stack on concrete floor or any other surface that emits moisture. Lay panels flat with proper support on the ends of panels. Do not stand panels on edge. All NRP® panels must be stored inside. Optimum storage conditions are 60° to 75° (16°C to 24°C) and 20% to 40% relative humidity. PLAS-TEX® panels must be stored flat on a smooth, dry surface. Before installation allow panels to come to room temperature. Install panels at the temperature typical for the area after construction is finished.

Parkland™ Plastics

All Parkland™ NRP® brand panels are made from solid reclaimed PLAS-TEX® material.

PLAS-TEX® interior panels are the same material all the way through. The front side may be embossed or coated to enhance appearance or durability. The back side is treated to accept recommended adhesives. PLAS-TEX® panels comply with California's Proposition 65 and the Canadian Food Inspection Agency requirements.

CLEANING PLAS-TEX® AND OTHER NRP PRODUCTS

After installation panels may be cleaned with non-abrasive all-purpose cleaners or soaps. For difficult stains such as felt marker and graphite, use mineral spirits or acetone sparingly. Parkland Back Labels can be soaked off with soapy water or penetrating oil such as WD-40.

Installation Preparation

Pre-Conditioning

Before beginning the installation, the installer must determine that the environment of the jobsite meets or exceeds all requirements specified in the installation guide. Prior to installing, read and remove all packaging and panel stickers and allow the panels to acclimate to the room temperature and humidity for 24 hours. Acclimation temperature range should be 60°F to 75°F (16°C to 24°C) and relative humidity should be 20% to 40%. Both the room temperature and humidity during acclimation and installation need to be the same as the final operating conditions.

Installation Conditions

Installation should not begin until building is enclosed (windows and doors are installed), permanent heating and cooling equipment is in operation, and residual moisture from plaster, concrete, or terrazzo work has dissipated. Installation temperature range should be 60°F to 75°F (16°C to 24°C) and relative humidity range should be 20% to 40%. Install panels only at the temperature and humidity typical for the area after construction is finished.

Panel Inspection

All Parkland panel products are inspected and believed to be defect free prior to shipment; however, all panels must be inspected for any defects prior to installation. Panels may possess slight imperfections on the back or edges which do not affect performance and are not cause for rejection. The installer assumes all responsibility for full inspection of product before installation. If panels are not acceptable, contact your Customer Service Representative (CSR) immediately. Do not install panels of unacceptable or questionable quality. Parkland Plastics, Inc. will not be responsible for installation or removal costs of unacceptable panels.

Wall Preparation

Walls should be clean, flat, dry, solid, and even. Remove high spots and fill in low spots prior to beginning installation. Remove any foreign matter that may interfere with the adhesive bond. The wall substrate must be dry and free from dirt, dust, and grease. Installation over uneven surfaces will result in little or no adhesion to the wall substrate, including bubbling due to air pockets forming behind the panel.

PRIMED FINISHED SUBWALLS

Painted finished subwalls and water-based (aqueous) recommended adhesives: For finished primed subwalls, use recommended aqueous adhesives including Parkland brand panel adhesive. For these situations you only need a 1/16" v-notched trowel to apply the Parkland Panel adhesive in these situations. Take cautions that the primer is not PVA-based- as these primers may interfere with some adhesive chemistry and limit bond strength.

SUBWALL TYPES

NEW PRIMED DRYWALL SUBWALLS: This is the ideal subwall. If all else is good, you are ready to install using a 1/16" V-notch trowel and Parkland Panel Adhesive.

NEW UNPRIMED DRYWALL SUBWALLS: Drywall joints need to be slick-taped with a setting joint compound. A finish coat is not necessary. The same conditions as apply as above- walls must be clean, flat, dry, solid, and even. Use a 1/18" V-notched trowel for these more-porous walls, as more of the adhesive will soak into the wall during application.

EXISTING SUBWALLS: Need to be inspected for compliance with the rest of this guide.

PLYWOOD SUBWALLS: Plywood walls must be clean, dry, flat, solid, and even. Warped plywood must be replaced. Water-based (aqueous) adhesives cannot be used over any waterproof (pressure treated or fire-treated) materials.

Parkland™ Plastics

MASONRY SUBWALLS: Concrete block, brick, and poured concrete walls are by nature uneven, and NRP panels installed directly to these surfaces will likely develop loose spots, bulges and buckles. They also tend to condense water and may be chronically damp. An alternate method is to install gypsum board, cement board or another appropriate substrate over furring and then install NRP panels according to the standard installation instructions. If it is the owner or contractor's preference to install NRP panels directly to a concrete block or brick wall, it is recommended that the panels be installed with Parkland Panel Adhesive using the included masonry subwall attachment method on pages 7 and 13 .

NON-POROUS SURFACES

Non-porous surfaces (ceramic tile, glazed block, moisture resistant substrates, and metal surfaces) do not provide a good surface for adhesion. Most adhesives will not dry properly to a non-porous surface. Special etching chemicals and ceramic primers will be needed and tested for satisfactory results prior to commencement of work.

Environmental Considerations

The following special conditions requiring additional preparation or installation techniques:

DIRECT SUNLIGHT: Direct sunlight on interior materials, including sealant and panels, may cause fading and/or rapid expansion depending upon amount of heat buildup. Use caution in these areas.

HIGH HUMIDITY ROOMS: Acclimate panels for longer periods of time in higher humidity conditions. Carefully review the guidelines herein for expansion/contraction spacing and sealing. (see Expansion Joint Chart, pg 5). Failure to properly seal moisture entry points or provide sufficient expansion space may cause swelling of the substrate resulting and warping, curling, delamination or adhesive bond failure. Use an adhesive that is recommended for higher humidity conditions. Installation of insulation and/or a vapor barrier may be required- and you should consult the Project Engineer or Architect in these circumstances for a proper fix that will not trap moisture or cause other problems. Check applicable building codes for specific requirements.

LOW and HIGH TEMPERATURE CONDITIONS: Acclimate panels to the temperature conditions the area will be during occupancy, and only install Parkland panels when the building space is also set to these same conditions. Carefully review the guidelines in this installation guide for expansion spacing and sealing (see Expansion Joint Chart, pg 6). Use an adhesive that is recommended for the appropriate temperature conditions. Installation of insulation and/or a vapor barrier may be required- and you should consult the Project Engineer or Architect in these circumstances for a proper fix that will not trap moisture or cause other problems. Check applicable building codes for specific requirements.

ISOLATED HEAT and WATER SOURCES: NRP and FRP panels will discolor over time when installed behind or near a heat source which radiates temperatures exceeding 130°F (55°C), such as cookers, ovens, and deep fryers.

EXPOSED MASONRY AND METAL SURFACES: Masonry materials conduct heat 17 times more effectively than drywall and cools the adjacent air to the point that air-bound moisture falls out of suspension and wets the surface. This wetting is chronic and never stops and can cause rot in even the best systems and materials. Masonry and metal surfaces are best covered with insulation or a waterproof covering to prevent chronic moisture problems from seeping into the subwall. Consult the Project Engineer or Architect for an appropriate solution.

Adhesive Selection and Application

The following information provides assistance on selecting the appropriate adhesive for installation:

PARKLAND PANEL ADHESIVE is the most-preferred adhesive material for most applications.

Parkland Panel Adhesive is ideally suited for porous and most non-porous substrates for interior applications. Parkland Panel Adhesive is mold-resistant and adheres to most substrates, including primed and unprimed drywall, greenboard, steel, foam board, vinyl, FRP, ceramic tile, laminate, sealed and unsealed concrete.

PLAS-TEX® panels should be installed using Parkland Panel Adhesive wherever possible. This adhesive is applied to the wall, rather than the panel for most installations. It has a long open time for ease of installation, and tacks up for instant panel grab. Use a 1/16" or 1/8" notched trowel depending on the subwall (see chart page 6) to spread the adhesive. Be sure to cover the entire area. The adhesive will go on milky and turn clear when it is ready to bond. This adhesive may be used with non-porous surfaces, such as DensArmor Plus®, Green Board or primed drywall. Complete installation instructions can be found on the can label or on our website. Adhesive coverage is about 1/3 gallon per 4' x 8' panel. Other adhesives may be used in variety of situations- please see adhesive selector chart on page 6.

Parkland™ Plastics

APPLYING ADHESIVES OTHER THAN PARKLAND PANEL ADHESIVE. All Parkland Performance wall coverings are waterproof. If water-based adhesives are used then as the adhesive dries that water will need to dry into the subwall. All latex, non-flammable, and aqueous adhesives may not be able to penetrate and dry properly over primed, or other sealed or moisture-resistant subwalls. Parkland Panel Adhesive is the only aqueous adhesive that bonds over most sealed walls. Be careful in planning your installation that there is somewhere for the water to go if using water-based adhesives. Sometimes wall finishes that are water-resistant must be removed or otherwise perforated or prepared. See wall perforating procedure elsewhere in this guide on page 7. Always check with the product manufacturers recommendations for whatever products you are using. Always follow all published Parkland use and care, installation, application, engineering and layout guidelines, along with all local, state and federal codes.

PARKLAND NRP and FPR PANELS ADHESIVE SELECTOR CHART

Substrate	Parkland Adhesive	Franklin Titebond Fastgrab FRP Adhesive	Liquid Nails FRP 310	3M High Strength 90 Spray Adhesive
Standard unpainted drywall	1/8" V-Notch Trowel	Yes	Yes	No
PVC-primed Drywall	No	No	No	Yes
Water-based primed drywall	Yes, 1/16" V-Notch Trowel	No	No	No
Oil-based primed drywall	Yes, 1/16" V-Notch Trowel	No	No	Yes
Cement board	Yes, 1/8" V-Notch Trowel	No	No	No
Raw Plywood	1/8" V-Notch Trowel	Yes	Yes	Yes
Treated Wood	1/8" V-Notch Trowel	No	No	No
Greenboard	1/8" V-Notch Trowel	No	Yes	No Unless Painted
Fiber Cement Board	1/8" V-Notch Trowel	No	No	No
Ceramic tile	Yes, [1]	No	No	Yes
Brick, CMU Block	Yes, [2]	No	No	No
Poured Concrete	Yes, [2]	No	No	No
XPS Polystyrene	1/8" V-Notch Trowel	No	No	No
Open Cell Foam	1/8" V-Notch Trowel	No	No	No
Foil-Faced Foam	No	No	No	Yes
Galvanized Metal	No	No	No	Yes
Aluminum	1/16" V-Notch trowel	No	No	Yes
Rusty Metal	No	No	No	No

[1] Etch tile first with appropriate etching compound (Zinsser, etc.);

[2] See CMU subwall instruction on p 7.

Parkland™ Plastics

PARKLAND NRP and FPR PANEL GAP SIZE CHART

PANEL SIZE	4' x 8'	4' x 9'	4' x 10'	4' x 12'
NRP Gap around rivets	1/8"	1/8"	3/16"	3/16"
NRP Gap between panels and wall fixtures	1/8"	1/8"	1/4"	1/4"
FRP Gap around rivets	1/16"	1/16"	1/8"	1/8"
FRP Gap between panels and wall fixtures	1/16"	1/16"	3/16"	3/16"

Subwall Identification and Trowel Techniques

IDENTIFICATION

- **Dry Subwalls:** Interior, upper floor, away from water and moisture sources with normal construction
- **Wet or Damp Subwalls** (First floor, ground contact, exterior wall, masonry, concrete, exposed metal, near sources of water or moisture)

TECHNIQUES

- Proceed with appropriate installation method
- Do not install over wet or damp walls
- **Smooth primed Subwalls:** Smooth primed or painted drywall or plaster
- **Rough, unprimed or bare plywood subwalls**
- **Dry Masonry** - (Brick, CMU block, or concrete walls)
- Use a 1/16" V-notch trowel for Parkland adhesive, and check with manufacturer for other adhesive use
- Use a 1/16" V-notch trowel for Parkland adhesive, and check with manufacturer for other adhesive use
- Use Parkland panel adhesive and a 3/16" square-notched trowel and apply adhesive directly to panel (in lieu of wall application).
For other adhesives- see manufacturer's recommendations.

Pre-Installation Planning

- Pre-fit each panel before fastening and/or adhering in place.
- Cutting and drilling should be done prior to the application of adhesive, and in a separate area to preclude dust contamination.
- Pre-plan for cove or base molding. NRP panels should be installed so that the base molding will not restrict normal panel movement during expansion and contraction. Cut panels 1/4" short of where the base molding will extend; poured acrylic floor with built-in base cove should be in place prior to installation.
- When using rivets, pre-drill holes in the panels using a drill bit that is 1/4" larger than the rivet. Plan ahead so that fasteners will not interfere with moldings or other wall fixtures.
- When using mechanical fasteners through NRP to attach wall angles or other fixtures, pre-drill holes using a drill bit that is 1/4" larger than the mechanical fastener. Without over-sizing the holes, the NRP will likely have bulges and/or buckles when panel movement occurs during expansion and contraction.

Basic NRP Panel Installation Steps

1. Trim panel to fit. Oversize pilot holes for all penetrations (please allow for proper expansion and contraction).
2. Radius corners of any cut-out or fixture openings.
3. Apply adhesive to 100% of the wall area using a cross-hatch pattern using a trowel recommended by the adhesive manufacturer.
4. Place panel on wall, leaving appropriate room at panel joints and corners for expansion and contraction.
5. Using a laminate roller, remove air pockets by rolling down and out toward the panel edge without a molding.
6. Fit appropriate moldings to panels edge leaving a minimum of 1/8" for expansion between panel and molding stem.
7. Install next panel.

The nature of NRP panels (and building themselves) is to expand and contract over time. Without leaving required room for expansion and contraction, panels can develop buckles and/or bulges because panel movement will occur.

Adhesive Selection and Application

POSITION PANEL FACE DOWN ON A COVERED WORK AREA

When cutting with a circular saw, position the panel so that the saw blade enters the back side of panel first to avoid chipping or damage. Cutting tools and methods per the experience and judgment of the installation professional per actual field conditions and the desires of the end user.

Radius Corners of Cut-Outs

CUT-OUTS: The inside corners of all cut-outs must have a radius of at least 1/8" (3.2 mm). Failure to radius corners may result in stress cracking. For pilot holes, a 1/4" (6.36 mm) diameter router bit or drill bit may be used, use a jig saw to complete the radius cut out. Allow 1/8" (3.2 mm) clearance around all fixtures, electric boxes, piping, etc.

PANEL SIZE	4' x 8'	4' x 9'	4' x 10'	4' x 12'
Gap around rivets	1/8"	1/8"	3/16"	3/16"
Gap between panels and wall fixtures	1/8"	1/8"	1/4"	1/4"

Attaching to Wall

Generally, NRP panels can be installed using adhesive alone or a combination of adhesive and fasteners. The method used should be determined by the room and wall conditions (see the wall conditions noted on pages 4 & 5). Check your local building codes for any restrictions or guidelines regarding approved installation methods.

Before starting, determine which seam treatment is being used (panels sealed together or panels joined with moldings). Please refer to the appropriate instructions for the type of seam treatment being used.

Applying Adhesive

When adhesive is used, be sure to use Parkland Panel Adhesive or a suitable non-flammable FRP panel adhesive. FRP panel adhesives are widely available, and be sure to follow the respective manufacturer's installation instructions. Follow the adhesive manufacturer's recommendations for trowel style (e.g., appropriate height of adhesive bead left by trowel). It is important to apply adhesive carefully and follow all directions to prevent problems that may result from using too little or too much adhesive (Figure 1).

NAILING: Panel weight may be temporarily supported with two brads or staples at the top corners and notching molding back flange around nails.

TROWEL ADHESIVE APPLICATION ON GYPSUM: Use Parkland panel adhesive or recommended equivalent adhesive for your project. Un-sealed or porous surfaces or high temperatures may shorten open time of the adhesive. Apply panel adhesive in a horizontal pattern directly to the panel backside or the wall. Leave only ridges of adhesive. For best results, apply panel to wall prior to adhesive set time, but after tack time (if applicable). Use pressure roller to roll panel into adhesive bed, and re-roll 20 & 60 minutes later.

Adhesive coverage is about 1/3- 1/2 gallon per 4' x 8' panel. Allow 7 days cure at 70 °F.

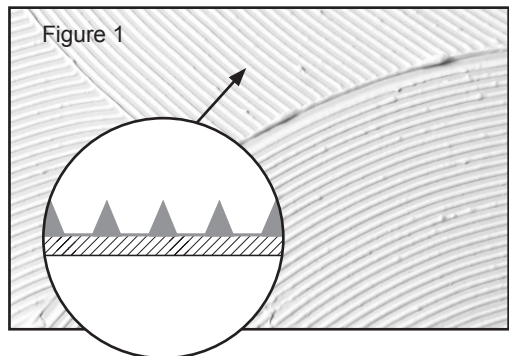

Spacing

All buildings expand and contract with seasonal changes, changes in humidity, temperature, sunlight, radiant and local heat sources, along with localized sources of moisture. All building panels also expand and contract with the same factors- sometimes in the opposite direction of the building. Parkland NRP panel installation systems have the necessary expansion characteristics pre-engineered to manage these dimensional changes. Adequate space must be allowed for panel expansion and contraction. For a 4' x 8' panel, a minimum gap of 1/4" is required at the top and bottom of each panel and 1/8" between panels. More room will be required for longer panels. It is recommended that panels do not exceed 48" in width and 12' in length to aid in ease of installation and ensure a satisfactory finished installation. See the NRP panel Expansion Gap Chart for appropriate spacing at floor and between panels. **When a moisture resistant installation is required, silicone sealant should be applied in all moldings around all panel edges, fastener, and fixtures.**

Refer to seam treat options for specific expansion joint chart.

SPECIALTY FASTENER OPTIONS

PIN RIVETS: Panels can be installed using plastic pin-rivets to further secure panels to walls. Panels properly installed with Parkland Panel Adhesive do not require mechanical fasteners. Pre-drill all rivet holes oversize 1/8" in the panel and seal with sealant. Ensure panels & moldings are fully bedded in adhesive, and fasten pin nails to wall. Approved patterns are every 16" o.c., in one direction, both directions, or along one panel edge.

The recommended fastening frequency is 16" on center both horizontally and vertically. Space perimeter holes at least 1" to 1-1/2" from panel edge when using one piece moldings and stagger holes of abutting panels. When using two piece moldings put perimeter holes 1-1/2" to 2" away from panel edge.

Panel and Seam Treatment Sequence Options

Depending on your seam treatment selection, panels are either installed in sequence with the seam treatment or panels are installed independently. Before starting, determine which seal treatment is being used. Select from one of the three options below:

1-PIECE MOLDING AND PANEL METHOD (Figure 2)

When using 1-piece moldings, panels and moldings are installed in sequence.

2-PIECE MOLDING AND PANEL METHOD (Figure 3)

When using 2-piece moldings, moldings are installed first

PANEL AND SEALANT METHOD (Parkland FRP Only)

When using sealant, all panels are installed prior to sealant application. Before sealant can be applied, installed panels need to be adhered for at least 6 hours

Before starting, determine which seam treatment is being used.

Molding and Panel Methods

One-piece moldings and two-piece moldings, both feature expansion-control guides and are available for installation with all solid color NRP family and Parkland FRP panels. One-piece moldings slip behind and between panels. Two-piece molding are installed with the female piece behind panels and the male (divider cap) set on top of the panels afterwards (Figure 3) Both systems create the appropriate cavity for the sealant to have a water-resistant seal, and allow for proper expansion. See Panel Gap Guide on Page 7 above.

SETTING MOLDINGS

1. Start in an inside corner. Mark plumb line 48-1/8" from the nearest edge (e.g. "out of plumb") of the corner. The first panel should be set true with a plumb line. Note: If the panel is supplied with a protective tack film, leave film on during installation. Peel back tack film approximately 1/2" for easy insertion into moldings. Remove film after installation.
 2. Place first panel against wall and align leading edge with plumb line.
 3. Insert a divider bar on the first panel up to expansion control guide and continue installing panels. The free edge of the molding or division bar may be tacked in place either with fasteners or contact adhesive if preferred before installing next panel. (Figure 2)
 4. Use a laminate roller to ensure all air pockets are removed between the panel and the wall and to ensure a good bond between the panel and the wall. Re-roll the panel as needed or as recommended herein per the site conditions.
- NOTE:** If using cap at the top or bottom of panel, slide it completely on to panel and maintain recommended expansion spacing. When not using cap at top and bottom, leave 1/4" (3.2 mm) gap for expansion. If a moisture resistant installation is required, silicone sealant should be applied in all moldings and around all panel edges, fasteners and fixtures.
5. Install the last panel on the first wall as stated above, but with no corner molding on the leading edge. The first panel on the new wall will receive a corner molding, thus completing the corner transition.
 6. Slide the next panel into the divider bar. Repeat process working in one direction around the room.

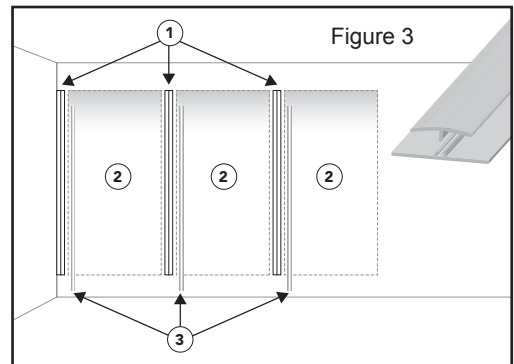
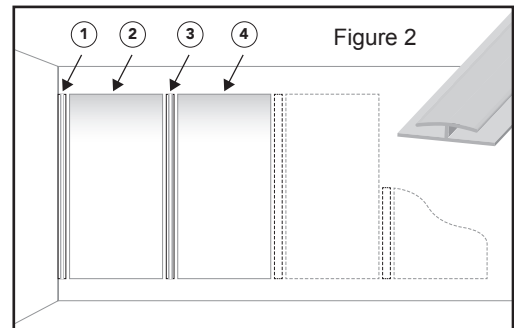

“Sealant and Panel” Method and Variations

(For Parkland FRP Only)

1. Start in an inside corner. Mark plumb line 48 1/8” from the nearest edge (e.g. “out of plumb”) corner. The first panel should be set true with this plumb line.

NOTE: If panel is supplied with a protective cover film, leave film on during installation with this method.

2. Apply 100% adhesive coverage to the entire back side (in lieu of the standard NRP adhesive application of applying glue directly to the wall) of the panel using a “crosshatch” type pattern. Place panel against wall and align leading edge with plumb line. Use caution to keep adhesive out of the panel gaps.*
3. Use a laminate roller to ensure all air pockets are removed between the panel and the wall and to ensure a good bond between the panel and the wall. Start in the top corner and begin rolling down and out towards the leading panel edge.
4. Hammer six-penny finishing nails against the panel leading edge two feet on center. This will maintain proper spacing between panels. **Leave nails in place until adhesive sets up (per adhesive label instructions) and then remove (Figure 4).
5. Prepare the joints for sealant.
 - If panel has tack film, leave in place.
 - If panel does not have tack film, place painter’s tape on panel along each side of the seams that are to receive sealant
6. Fill the 1/8” (3.2 mm) gap between the panels with sealant, making sure that the gap is completely filled. Push tube in the direction of travel (Figure 5). For the best results use the “two-cloth” method on page 11.
7. After smoothing bead, allow sealant to gel before removing tack film or painter’s tape.

If using a cap at the top or bottom of panel, slide it completely on to the panel. When not using a cap at the top or bottom, leave 1/4” (3.2mm) gap for expansion. If a moisture resistant installation is required, Silicone sealant should be applied in all moldings and around all panel edges, fasteners and fixtures.

Standard Seam Sealant Application

(For Panel Installations with Moldings)

SEALANT SELECTION GUIDELINES:

Recommendations in selecting an ideal sealant for the project at hand.

- Wherever possible Acetoxy-free silicone sealant is most desired where a strong bond to the panel is desired.
- Silicone and polyurethane sealant materials in general are most preferred where a tough use environment is anticipated.
- Water-based sealant is suitable most standard installations
- Generally most sealants available in a supply store follow the rule of you get what you pay for and most 10 oz. tubes that cost half the premium offerings provide substantially less performance than the premium offerings.

WALL PREPARATION

1. Surfaces should be free of grease, dirt, and other contaminants. Clean seams as necessary with a dry, lint free rag or a rag dampened with solvent if necessary (Figure 6).
2. Installed panels need to be adhered to the wall for at least 6 hours before beginning seams.
3. Remove any adhesive between the panels with a putty knife or “5-in-one” painter’s tool..
4. Prior to dispensing sealant, apply painter’s tape on each side of the seam. Tape needs to be applied exactly along the panel edge. If panel has a pre-applied tack film, peel back about 1/2” along each seam so the painter’s tape can bond to the panel face (Figure 9 page 12).

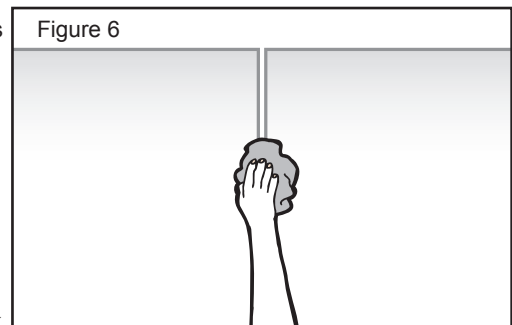
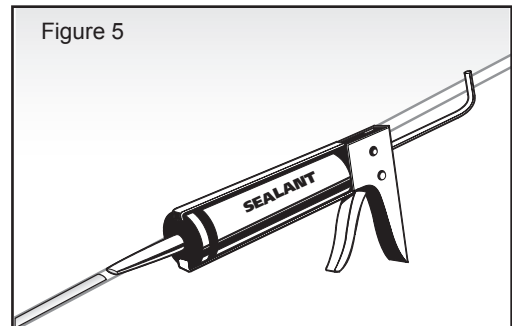
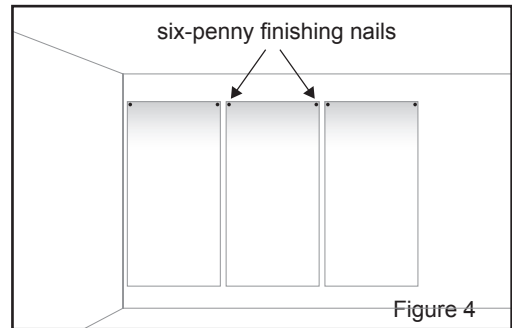

SEALANT PREPARATION AND APPLICATION (Figure 7)

1. Loading a cartridge into a dispensing gun
 - A. Select an appropriate sealant from the table on page 16.
 - B. Remove the plastic tip from the end of a sealant cartridge.
 - C. Check, and pierce if necessary, the inside end of the cartridge.
 - D. Load cartridge into dispensing gun ensuring that the cartridge is lined up properly.
2. Mind the open time of the sealant (the amount of time you have to use the sealant) so it will create strong bond and seal.
 - A. For urethane sealant, the approximate open time is 5- 30 minutes at 75°F (24°C).
 - B. Open time will fluctuate as temperature increases or decreases, and with brand and type of adhesive. A rule of thumb is that for every 18°F (10°C) increase in temperature, the open time will be cut in half.

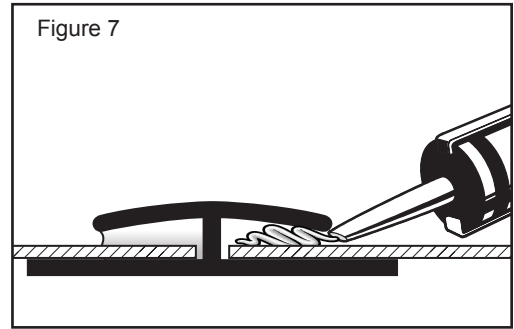

HERE IS OUR MOST-RECOMMENDED SEAM DRESSING METHOD:

A. “Two-Cloth” Cleaning Method for Smoothing Sealant

The two-cloth cleaning method consists of a solvent wipe followed by a dry cloth wipe to lift and remove the solvent and contaminants suspended in the solvent. Multiple cleanings may be required to properly clean a substrate.

1. Pour a small amount of ISP Alcohol [Rubbing Alcohol] onto a cloth.
2. Wipe vigorously to remove contaminants. Check the cloth to see if it has picked up contaminants. Rotate the cloth to a clean area and re-wipe until no additional dirt is picked up.
3. Immediately wipe the cleaned area with a second clean, dry cloth before the solvent has evaporated. This technique will allow dirt and contaminants suspended in the solvent to be lifted and removed with the second dry cloth. Porous surfaces or humid weather conditions will require a small amount of dry time to allow the substrate to be completely dry prior to application of sealant.

B. APPLICATION: For a water-resistant installation, place a continuous bead of waterproof Sealant in all molding channels and mating flanges. Aim the sealant cartridge slightly forward. And keep even pressure on the cartridge as you move forward along the joint. Excess sealant can be cleaned off while fresh.

C. CLEAN-UP: After application, excess sealant may be removed using *Bostik® Hand Towel and Specialty Adhesive Remover*, or with a rag and isopropyl or denatured alcohol. Allow 48 hours cure before use. After curing, clean with soapy water. See clean-up section on page 13.

APPLYING WATER-RESISTANT SEALANT TO SEAMS and JOINTS

1. The size of the installation team is **per the experience and judgment of the installation professionals per actual field conditions and the desires of the end user.**
2. If one operator is used, then each seam will have to be processed individually (filled and then smoothed by the same operator before moving on to the next seam). A new mixing tip may be preferred to be used for each seam in this case.
3. For multiple operators (two or more), the end user may design the process such that one operator can dispense, while a second operator can follow and smooth the joints. Care will need to be taken to ensure that the open time of the material is not exceeded.

VERTICAL FLAT PANEL SEAMS

1. Vertical Seams should be processed first as they are intended to be smoothed flat with the panel. Inside corners, floor joints are smoothed such that the seam sealer stands proud of the surface, which would require placement over any vertical seams that may interface with these joints (Figure 8).

2. Material should be dispensed into each seam at a rate such that the seam is completely filled with sealant within the sealant's open time. It is recommended that sealant is installed in sections no longer than 3' for all panel length as a bench mark. Section length will vary dependent on environmental conditions at job site. page 10 pic

It is recommended to pull dispensing gun away from bead during application.

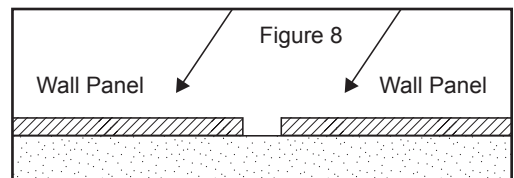

3. A good technique is to add a small horizontal piece of painters tape every 3' and ensure that there is enough sealant in the cartridge to complete a full seam. Performing a cartridge change in the middle of a seam application could increase the risk of exceeding the open time of the sealant (Figure 9)

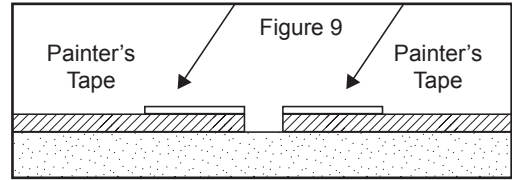

4. If the seam has a large gap and/or cannot be filled by the sealant in one pass, an initial "filler bead" can be applied and then a secondary bead can be applied over the top of the initial bead after initial bead has reached full cure. Weatherstripping putty, may also be used to fill large gaps prior to the application of the urethane seam sealant (Figure 10).

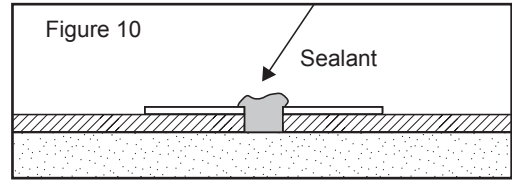

Smoothing the sealant: (putty knife)

A. After the sealant has been dispensed, smooth the sealant beads flush with the panel surface using a seam finishing tool or a smooth cotton rag per the experience and discretion of the installer and the desires of the end user.

B. Smoothing of the sealant must occur within the open time of the sealant.

C. As soon as the smoothing of the sealant is complete, remove the horizontal painters tape.

5. Remove horizontal tape and begin next 3' section. A good technique is to apply the sealant below the previous section and "bump up" the sealant into the previous section.

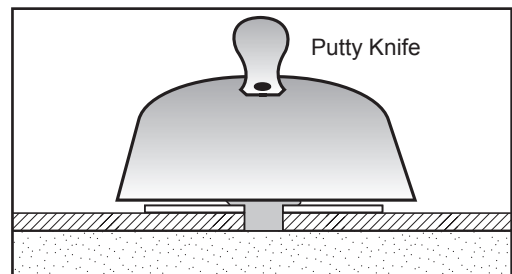

6. Once the all sections of the wall are completed, remove the vertical painters tape. Remove Any excess sealant- panels can be cleaned using the recommendations in the clean-up section of this guide (Figure 11).



VERTICAL OUTSIDE CORNERS

For Vertical outside Corners, repeat process steps 1-6 as listed in Vertical Flat Panel Seams

VERTICAL INSIDE CORNERS

1. Repeat process listed in Vertical Flat Panel Seams except for the format to smooth the sealant.

2. Smooth the sealant beads flush with the panel surface using a coving tool or smooth cotton rag (which may need to be damp with ISP per the sealant type).

A. A flush or "Inline" seam tool or putty knife can also be used if a flat inside corner bead is desired, per the experience of the installer and preference of the customer.

B. Smoothing of the sealant must occur within the open time of the sealant.

C. As soon as the smoothing of the sealant is complete, remove the painters tape. Any excess sealant on panels can be cleaned using a solvent dampened rag.

HORIZONTAL FLOOR AND CEILING JOINTS

1. Material should be dispensed into each seam at a rate such that the seam is completely filled with sealant but completed within the sealant open time.

2. It is recommended to pull dispensing gun away from bead during application.

3. Ensure vertical seams are cured prior to processing horizontal seams.

4. It is also recommended that operators ensure that there is enough sealant in the cartridge to complete a full seam. Performing a cartridge change in the middle of a seam application may increase the risk of exceeding sealant open time.

5. If the seam has a large gap and/or cannot be filled by the sealant in one pass, an initial "filler bead" is best used prior to final bead application. The filler bead must be at least gelled prior to final bead application.

6. Smoothing the Sealant (this is technique-based work and varies by individual):

- A. Smooth the sealant beads flush to the panel face using the radial seam finisher if a rounded corner joint is desired.
- B. Use an inline seam finisher for flat inside corner beads.
- C. Smoothing of the sealant must occur within the open time of the sealant.
- D. As soon as the smoothing of the sealant is complete, remove the painters tape.

Cleaning panels while the sealant is in its open time is much easier.

SEAMS AROUND DOOR AND WINDOW FRAMES OR OTHER SPECIAL APPLICATION AREAS

- 1. Repeat the process listed in Vertical Flat Panel Seams.
- 2. Material should be dispensed into each seam at a rate such that the seam is completely filled with sealant within the open time for the sealant. As these seams typically have a larger gap, they may not be able to be filled in one pass. You may need to use an initial filler bead or backer rod (pre-formed foam rod) to fill the gap prior to applying the final sealant.
 - A. Mechanical fillers such as weather-strip putty or backer rod may also be used to fill large gaps prior to the application of the Sealant.
 - B. IMPORTANT NOTE: Wider seams like these may lower the available open time during which the material can be successfully smoothed.

3. Smoothing the Sealant

- A. After the sealant has been dispensed, smooth the sealant beads flush with the panel surface. Since these joints are larger and often have an irregular shape, it is at the experience an discretion of the installer to determine the best method for smoothing the joint. A combination of common smoothing tools may be required. An inline seam finisher should be used for small in-line panel seams.
- B. Smoothing of the sealant must occur within the open time of the sealant.
- C. As soon as the smoothing of the sealant is complete, remove the painters tape. Any excess sealant on panels can be cleaned using an appropriate solvent dampened smooth white cotton rag.

Panel Installation Finish and Clean Up

Use a laminate roller to ensure all air pockets are removed and a strong bond is achieved between the panels and the wall. Start in the top corner of the panel and begin rolling down and out towards the panel edge without a molding. Panels should be re-rolled 15 minutes after installation and may be re-rolled again 60 minutes and finally 2 hours after installation if necessary.

CLEAN-UP

Adhesive residue may make panels appear stained and collect dirt over time. Remove any adhesive residue upon completion of the job. Remove latex-based adhesive with a soft cotton cloth and warm soapy water. Change water and cleaning rags frequently. For clean-up with solvent based adhesives, use isopropyl alcohol, mineral spirits, or acetone sparingly with a soft smooth white cotton rag.

Alternatively, panels may be cleaned with non-abrasive cleaners such as *Bon Ami*. *Bostik® Hand Towel and Specialty Adhesive Remover* also do a great job of cleaning most adhesive residue from panels. .

Speciality Installations

Using Parkland Performance Panels in Specialty Applications

MASONRY SUBWALL INSTALLATIONS

Use Parkland panel adhesive and a 3/16" square-notched trowel and apply adhesive directly to panel (in lieu of wall application). For other adhesives- see manufacturer's recommendations (Figure 12).

WATER-RESISTANT INSTALLATIONS

In order to minimize gaps between the panel and the grid system, Parkland Composites strongly recommends NRP ceiling panels be used with butt-end ceiling grid systems. Smooth NRP panels will highlight the space between the grid and a flush mount ceiling panel. Parkland Composites is not responsible for space between panel and grid when overlay grid systems are used. For optimal results use Parkland SpectraTile.

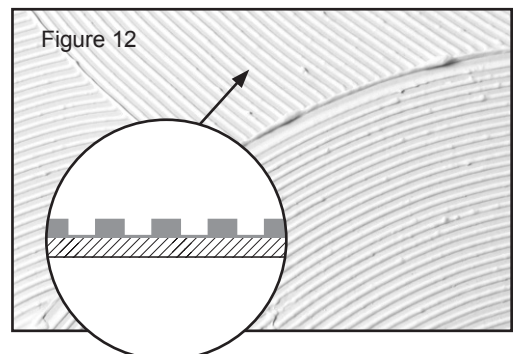

Waterproof Wall and Wet-Area Installations

Using NRP panels that have been factory laminated to fluted polypropylene is the ideal solution for lining the interior walls of a car wash, with its high moisture environment. The expansion and contraction due to thermal changes and extended exposure to moisture can, however, cause any NRP panel product to expand. Bulging from expansion can be minimized if panels are installed properly. The key to a satisfactory installation in such a high moisture environment is to provide adequate clearance around fasteners, moldings, pipes, and junctures so the panels are free to expand and contract. As little as 1/64" change in length can cause bulging if there is no clearance for a panel to expand.

Additionally, the following guidelines will aid in completing a satisfactory high moisture installation.

1. Limit panel length to 8'.
2. Install panels vertically.
3. Acclimate panels to the ambient temperature and moisture conditions for a minimum of 48 hours prior to installation.
4. Install panels leaving a minimum of 1" space at both the floor and ceiling junctures.
5. Use Parkland Panel Adhesive and Parkland NRP panels for the ultimate in moisture-resistance. Do not use mechanical fasteners (metal or nylon drive rivets).
6. Leave a minimum 4"- 6" gap between the bottom edge of the panels and the finished floor. Fill this area with DuroBase, and seal base to bottom of wall panels.

Using NRP panels that have been factory laminated to fluted polypropylene is the ideal solution for lining the interior walls of a car wash, with its high moisture environment. The expansion and contraction due to thermal changes and extended exposure to moisture can, however, cause any NRP panel product to expand. Bulging from expansion can be minimized if panels are installed properly.

Product Identifier (for Panels and Accessories)

Description and general properties of Parkland performance Panels

Wall Covering Types:

Use the grid below to identify and understand Parkland Panel Options.

Panel	Appearance	Fire Classification	Installation	Moldings
NRP	Monochrome	C (III)	Glue Up	1 and 2 pc.
NRP-FR	Monochrome	A (I)	Glue Up	1 and 2 pc.
Polywall	Monochrome	C (III)	Glue Up	1 and 2 pc.
PVC	Monochrome, Faux Finishes	A (I)	Mechanical Fastening	1 and 2 pc.
PLAS-TEX Thick Panel	Monochrome	Not Rated	Mechanical Fastening	1 and 2 pc.
Parkland FRP	Monochrome	C (III) and A (I)	Glue Up	1 and 2 pc.

Use and Care Guide (for all panels)

Proper Use and Care, Maintenance, and Repair instructions for Parkland Performance Panels

Panel Use Environments

Maintenance, Care, and Repair Instructions for Panels

ROUTINE CARE

Most Parkland™ NRP® products feature a textured or matte finish to help protect and beautify the surface. Soapy water, ammonia-based cleaners or common household surface cleaners will remove most dirt and residue from products. Stubborn residue will require a little stronger cleaner. Follow the recommendations below, in order, to properly clean your NRP® product. Always test in an inconspicuous area first.

The use of non-recommended cleaners may cause surface damage and should not be used on NRP® surfaces. Some chemicals are not compatible with NRP. While NRP is extremely chemical resistant and safe to use with bleach solutions, Betadine®, and most every other janitorial agent, it is always advisable to test any highly reactive solvent in an inconspicuous area prior to use. Surfaces exposed to these agents should be promptly flushed with water. Contact for even a short period of time can cause surface damage, spots, or discoloration. Follow the recommended restoration procedures described below as needed to its original condition. Severe damage caused by incompatible chemical contact will require product replacement. Do not place hot appliances on or in proximity with NRP surfaces.

STAIN REMOVAL:

- Warm soapy water
- Ammonia based liquid cleaner
- Oxalic acid solution and rinse
- A small amount of mineral spirits in a rag, and rinse

Tip: Wipe dry after cleaning to prevent a build-up of soap residue which can create the appearance of light scratches over time.

ROUTINE CLEANING

- Soapy Water
- Windex® Multi-Surface Cleaner with Vinegar
- Mild Detergent Solutions
- Clorox® Anywhere® Hard Surface™ Dailyr
- Formula 409® All Purpose Cleanse
- Kaboom® with OxiClean Stain Fighter
- Clorox® Clean-Up® Cleaner with Bleach
- Lysol® All Purpose Cleaner
- Fantastik® Oxypower® Multi-Purpose Cleaner
- Bon Ami
- Clorox Green Works® Natural Bathroom Cleaner*

RESTORATION

NRP surfaces may be repaired or restored in some cases.

- Dinged edges may be restored with medium or fine sandpaper or a laminate file, follow up with fine sandpaper, and a White 3M Scotch-Brite® pad.
- Fine scratches may be buffed out in some cases by wet-sanding with 320-600 grit paper, in multiple steps. Polish with toothpaste or car polish, and rinse.
- Dull finishes may be restored with polishes like Countertop Magic®, or Armor-All®.

SANITIZING

Parkland NRP is amenable to sanitizing procedures including the use of bleach solutions. Follow Sanitizing instructions set forth by governing body. Contact Parkland for more information.

SEALANT SELECTOR GUIDE

In general, sealants that are made from either polyurethane or silicone are the best performers and are preferred over water-based (aqueous) sealants which are typically inexpensive and do not resist moisture very well. For silicone sealants a neutral cure (Acetoxy-free) sealant is much preferred as it will typically bond much better to the stain-resistant finish on NRP family panels.

Parkland™ Plastics

Here are some preferred sealants that are commonly available:

MANUFACTURER	TYPE	PRODUCT NAME	BENEFIT
American Sealants Inc. (ASI)	Neutral cure RTV	ASI 335	Strong bond, flexible, white
Dow Corning	Neutral cure silicone, clear	#737	Strong bond, flexible, clear
General Electric	Neutral cure silicone, colors	G.E. Silicone II	Strong bond, flexible, choice of colors
CR Laurence	Neutral cure, colors	Silglaze II	Strong bond, flexible, choice of colors
Tremco	Polyurethane	Vulkem 116	Strong bond, flexible, white
DAP	Polyurethane	Premium Polyurethane Construction Sealant	Strong bond, flexible, choice of colors
3M	Polyurethane	3M Hybrid Sealant 755	Strong bond, flexible, choice of colors

Always choose the right materials for the job, and test for appropriateness of sealant prior to beginning work. Different sealant will have different characteristics which may be helpful for certain projects and field conditions. It is up to the experience and expertise of each individual installer to select materials that meet the desires and needs of their end user.

AN IMPORTANT NOTE ABOUT MOISTURE RESISTANT SUBSTRATES

MOISTURE-RESISTANT GYPSUM VARIES TREMENDOUSLY, WHILE SOME OF THESE NEW SURFACES ALLOW MOISTURE TO PENETRATE, OTHERS RETARD OR TOTALLY PREVENT PENETRATION OF WATER OR SOLVENT. TESTING BY PARKLAND PLASTICS INDICATED THAT WHEN WATER BASED ADHESIVES ARE USED IN CONJUNCTION WITH MOISTURE RESISTANT GYPSUM THE ADHESIVE ABILITY TO CURE IS SEVERELY COMPROMISED IN THE CRUCIAL

FIRST 24 HOURS OF INSTALLATION AND THE POTENTIAL FOR A SUCCESSFUL INSTALLATION IS GREATLY DIMINISHED. THE CONSTRUCTION TRADE IS BECOMING EXPOSED TO AN INCREASINGLY LARGE NUMBER OF NEW TYPES OF MOISTURE RESISTANT GYPSUM FROM THE DRYWALL INDUSTRY. GIVEN THESE TWO FACTS, IT IS RECOMMENDED THAT YOU CONTACT PARKLAND PLASTICS TECHNICAL SUPPORT DEPARTMENT, PRIOR TO ANY NRP INSTALLATION OVER WALL SUBSTRATES OTHER THAN STANDARD GYPSUM.

NRP® brand, Parkland FRP, and PLAS-TEX® PANELS physical properties vary by exact panel type. Please consult our published documents available on our website or consult your Parkland Performance Panel representative. Parkland Plastics cannot ensure code compliance in all situations.

FLAME SPREAD AND SMOKE DEVELOPMENT RATINGS

Published flame spread and smoke development ratings are made available for comparative purposes only, and are not intended to reflect alleged hazards presented by Parkland Plastics products under actual fire conditions. These ratings are determined by small-scale tests conducted by Underwriters Laboratories and other independent testing facilities using the American Society for Testing and Materials E-84 test standard (commonly referred to as the "Tunnel Test").

PARKLAND PLASTICS PROVIDES THESE RATINGS FOR MATERIAL COMPARISON PURPOSES ONLY. Like other organic building materials (e.g. wood), panels made of fiberglass reinforced plastic resins or Non-Fiberglass Reinforced Recycled Polymers will burn. When ignited, different types of NRP panel may produce different types and/or quantities of smoke. All smoke is toxic. Fire safety requires proper design of facilities and fire the correct fire-rated interior finish and fire suppression system necessary for a specific installation. We believe all information given is accurate, without a guarantee. Since conditions of use are beyond our control, all risks are assumed by the user. Nothing herein shall be construed as a recommendation for uses which infringe on valid patents or as extending a license under valid patents. www.astm.org/Standards/E84.htm.

NRP®, NRP-FR, Parkland™ FRP, and Polywall™ are Registered Trademarks of Parkland Plastics, Inc.

Parkland Plastics has achieved GREENGUARD [GOLD] Certification for their SpectraTile® Ceiling Tiles, NRP®, Polywall™, NRP-FR, DuroBase and POLYMAX® Wainscot products.

Parkland Plastics Inc. is the manufacturer of NRP®, NRP-FR, Parkland™ FRP, and Polywall™ and a variety of other innovative reclaimed polymer engineered composite building components. Inspired by the Parkland tradition of innovation in reclaimed engineered materials, Parkland Plastics has over 30 years of experience in commercial building products and is recognized as the inventor of NRP products.

